



## Dough Mixers

### 22lt Spiral Dough Kneader, 2 Speeds, removable bowl and tilting head

ITEM # \_\_\_\_\_

MODEL # \_\_\_\_\_

NAME # \_\_\_\_\_

SIS # \_\_\_\_\_

AIA # \_\_\_\_\_



**602356 (DSKTH22L)**

Spiral Dough Kneader 22lt,  
2 speed, Removable Bowl,  
Tilting Head,  
380-415V/3/50HZ

### Short Form Specification

Item No. \_\_\_\_\_

2 speed spiral dough kneader on wheels, with tilting head and motorized, removable bowl. Ideal for pizzeria, bakeries and pastries. Ingredients are kneaded with a stainless steel spiral mixer arm synchronised with bowl rotation (motorized not removable bowl). Body is in painted steel, the 22 lt capacity bowl, spiral mixer arm and dough breaker pin are in stainless steel. The safety screen allows ingredients to be added without stopping. Equipped with low voltage control panel with on/off switch, speed selection and timer (up to 30 min) or continuous mode. Safety device to stop the machine when the protection screen is opened. Tool speed: 84 and 168 rpm; bowl speed: 10 and 20 rpm. Maximum dough capacity: 17 kg per cycle (maximum 10,6 kg flour/cycle), with 60% hydration.

### Main Features

- Spiral dough kneader with tilting head and motorized, removable bowl.
- Two speed kneading for faster cycles (tool speed: 84 and 168 rpm; bowl speed: 10 and 20 rpm).
- Ideal for kneading pizza dough, bread or similar dough.
- Stainless steel (AISI304) squared dough breaker bar for fast and even kneading results
- Maximum kneading capacity: 17 kg per cycle (maximum 10,6 kg flour/cycle), with 60% hydration.
- Transparent protective screen to reduce flour dust release in the work area during kneading (EU EN453:2014) and to prevent dough contaminations.
- Minimum kneading capacity: 9 kg/cycle, with 60% hydration.
- Safety device stops the appliance if the cover is openend.
- Equipped with 4 wheels, of which 2 with brakes, allowing to easily move the appliance for storage or cleaning.
- The appliance fits under standard kitchen worktops (see installation drawing).

### Construction

- Additional bowl available as optional accessory.
- Constructed in painted steel.
- AISI304 stainless steel bowl, spiral hook and dough breaker bar.
- Control panel with on/off switch, speed selection and timer.
- Analogic timer up to 30 minutes or continuous mode.
- IP54 protected control panel.
- IP23 for the appliance overall.

### Included Accessories

- 1 of 22lt s/s bowl for tilting head spiral dough kneader PNC 653891

### Optional Accessories

- 22lt s/s bowl for tilting head spiral dough kneader PNC 653891
- 4pcs, fixed feet for spiral dough kneaders (only for 10/22/33lt) PNC 653894

APPROVAL: \_\_\_\_\_



## Dough Mixers 22lt Spiral Dough Kneader, 2 Speeds, removable bowl and tilting head

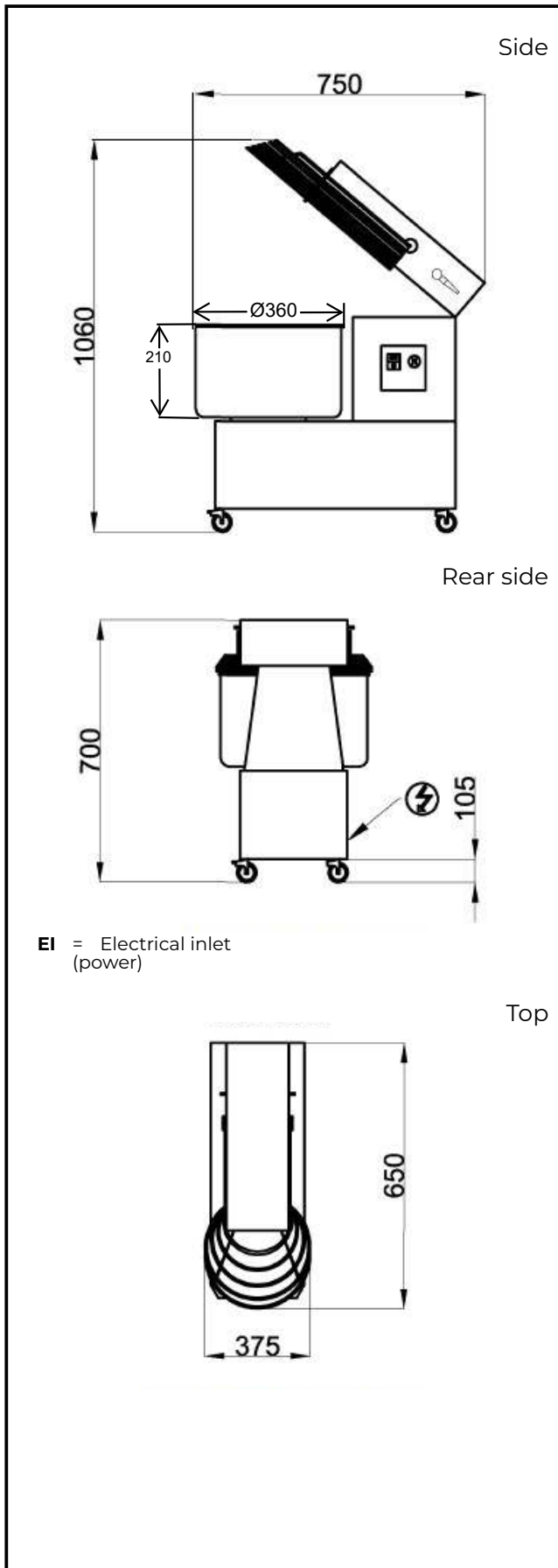

Electric

**Supply voltage:** 380-415 V/3 ph/50 Hz  
**Total Watts:** 1.5 kW

Capacity:

**Maximum kneading (60% hydration):** 17 kg/Cycle

Key Information:

**External dimensions, Width:** 375 mm

**External dimensions, Depth:** 650 mm

**External dimensions, Height:** 700 mm

**Shipping weight:** 89 kg

**Bowl capacity:** 22 lt



Dough Mixers  
22lt Spiral Dough Kneader, 2 Speeds, removable bowl and tilting head  
The company reserves the right to make modifications to the products without prior notice. All information correct at time of printing.

2026.05.18